

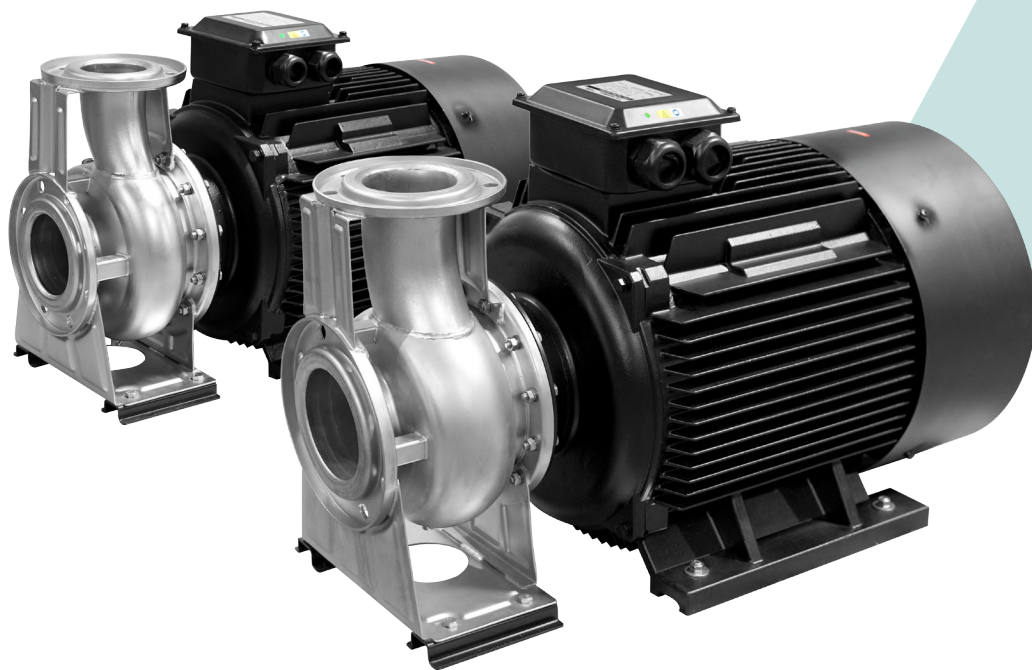

# MOTOBOMBAS DE SUPERFICIE



serie / **FLUX**

MODELOS DESDE 4 LPS HASTA 83 LPS  
CON POTENCIA DE 1.5 HP HASTA 120 HP

# FLUX

Es una amplia gama de motobombas centrífugas horizontales monoetapa, construidas en acero inoxidable. Sus técnicas avanzadas de fabricación junto con su diseño versátil, ofrecen una confiable solución a la mayoría de necesidades en el mercado.

# ALTAMIRA®

## APLICACIONES

- Sistemas de agua potable
- Sistemas de enfriamiento
- Sistemas contra incendio
- Actividades agrícolas
- Transferencia de líquido industrial
- Abastecimiento de agua
- Tratamiento de agua
- Sistemas industriales
- Edificios (hoteles, centros comerciales, oficinas, escuelas, hospitales, grupos de viviendas, etc.)

## VENTAJAS

- Amplia gama de modelos desde 4 lps hasta 83 lps
- Diseño compacto y robusto, fabricada a través del hidroconformado
- Optimización de la apariencia del motor a través de su diseño cuadrado
- Cuerpo de bomba tipo voluta
- Conexión hidráulica a través de contrabridas

## CARACTERÍSTICAS

### CONSTRUCCIÓN:

- Impulsor, eje, cuerpo y tornillería en acero inoxidable 304
- Sello mecánico en Carbón-Cerámica/NBR
- Empaque del cuerpo hidráulico en NBR

### OPERACIÓN:

- Rango de temperatura del líquido: 5°C a 70°C
- Máxima temperatura ambiente: 50°C
- Rango pH: 6 a 8
- Máxima presión de operación: 10 bar (145 psi)
- Densidad recomendada: 1 g/cm<sup>3</sup>

### MOTOR

- Asíncrono, dos polos
- Aislamiento clase F
- Totalmente cerrado enfriado por ventilador (TCCV)
- Protección térmica incorporada en equipos monofásicos
- Servicio continuo
- Grado de protección IP55

**2 AÑOS**  
GARANTÍA



**FLUX 4 / 1.5 3 234**

Serie

Caudal nominal en litros por segundo

Potencia nominal

Número de fases

Voltaje del motor  
234 = 230/460V



Las motobombas horizontales monoetapa serie FLUX están disponibles en 10 rangos de flujo, más de 40 rangos de presión y con potencias desde 1.5 HP hasta 120 HP, asegurando al consumidor que encontrará la más adecuada a su necesidad.

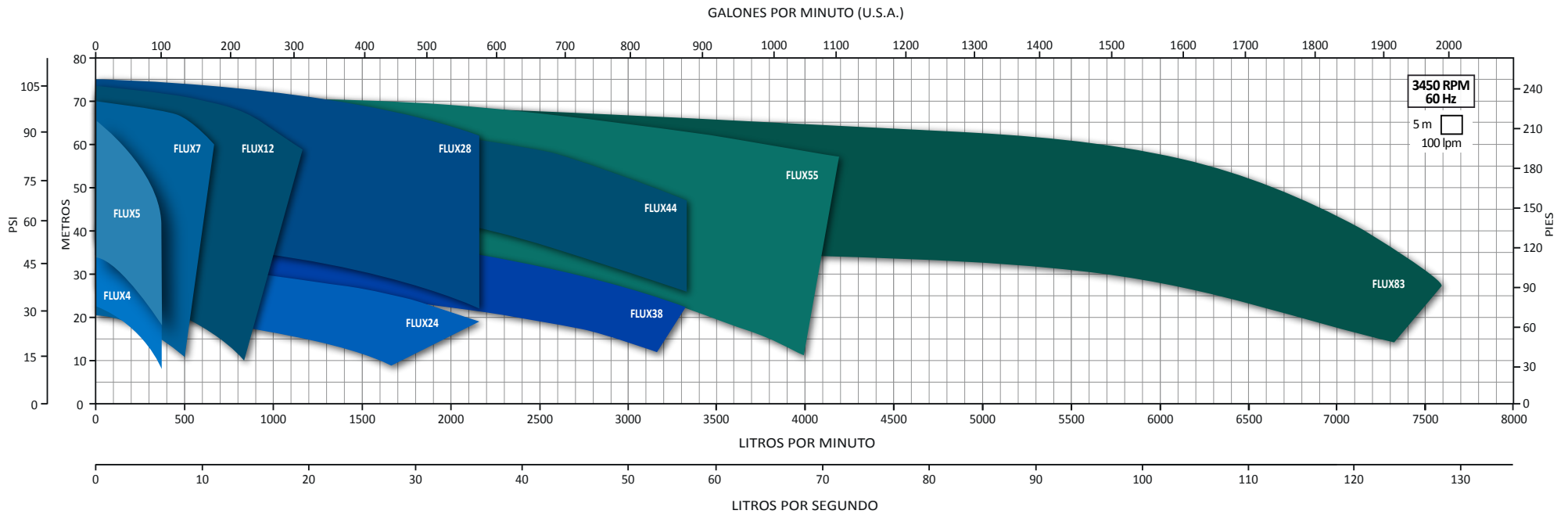

SERIE	CAUDAL NOMINAL		RANGO DE OPERACIÓN		RANGO DE POTENCIA
	LPS	GPM	LPS	GPM	HP
FLUX4	4	63	0.8 - 6	12.6 - 95	1.5 - 3
FLUX5	5	79	0.8 - 6.2	12.6 - 98	4 - 7.5
FLUX7	7	111	1.3 - 10	20.6 - 158.5	2 - 15
FLUX12	12	190	3 - 16.6	47.5 - 263	4 - 25
FLUX24	24	380	10.8 - 33.3	171 - 527.8	5.5 - 12.5
FLUX28	28	444	10.8 - 35.8	171 - 567.4	15 - 40
FLUX38	38	602	16.6 - 55	263 - 871.7	15 - 25
FLUX44	44	697	16.6 - 55	263 - 871.7	30 - 50
FLUX55	55	872	16.6 - 70	263 - 1110	25 - 75
FLUX83	83	1315	16.6 - 125	263 - 1981	60 - 120

**NUEVAS SERIES**

### CURVAS DE OPERACIÓN

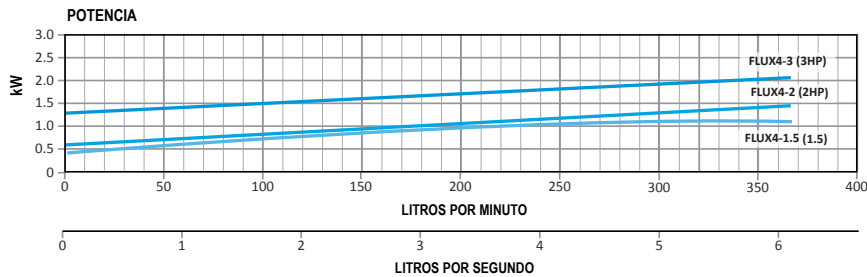
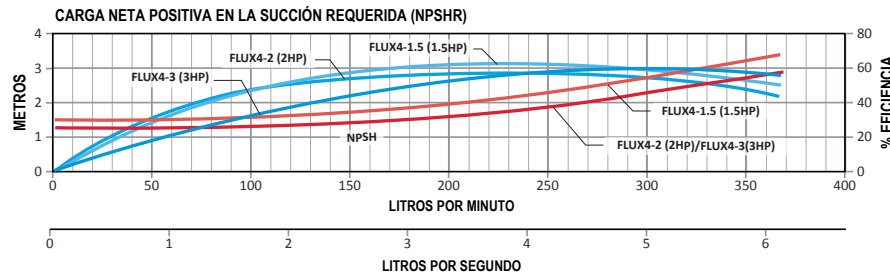
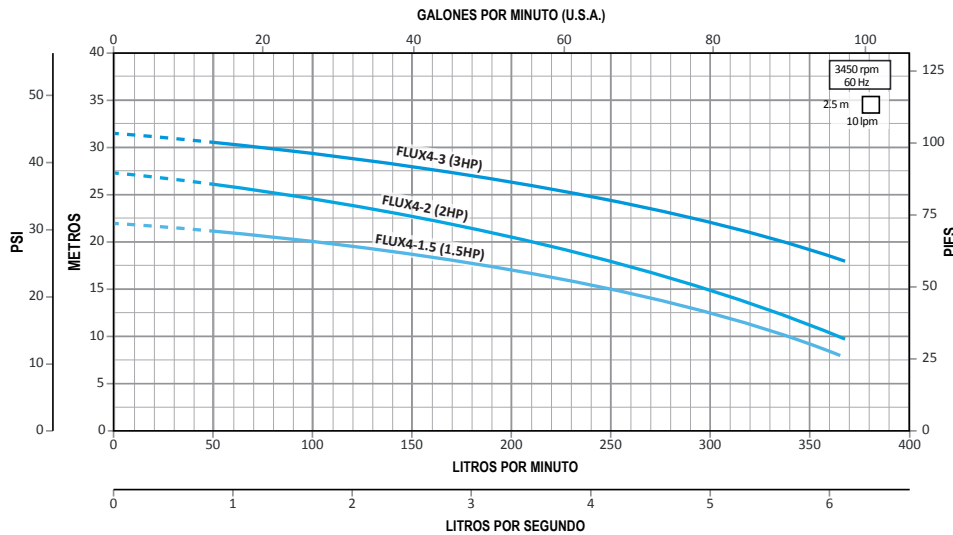

### TABLA DE ESPECIFICACIONES



Código	HP	KW	Fases x Volts	A	Succión x descarga	DMS*	Presión al cierre (m/psi)	Carga en metros (psi)											
								10 (14.2)	15 (21.3)	20 (28.4)	25 (35.5)	30 (42.6)							
								Gasto (litros por minuto)											
FLUX4-1.53234	1.5	1.1	3 x 230/460	5/2.5	2" x 1.25"	2.5"	22/31.2	316	250	100									
FLUX4-1.51230			1 x 230	7.5															
FLUX4-23234	2	1.5	3 x 230/460	7.3/3.7				27.5/39.5	366	300	208	83							
FLUX4-21230			1 x 230	10.2															
FLUX4-33234	3	2.2	3 x 230/460	9.5/4.8									31.5/44.7			333	233	75	
FLUX4-31230			1 x 230	14.5															

\*DMS: Diámetro mínimo recomendado para tubería de succión.

### KIT DE CONTRABRIDAS (venta por separado)



Código	Conexiones		Tipo de conexión	Material de construcción	Incluye	Peso (Kg)
	Succión	Descarga				
FLUXKB-DN2X1.25	2"	1.25"	Rosca NPT Hembra	Acero inoxidable 304	Contrabridas, empaques, tornillos y tuercas	3

NOTA: Se recomienda el uso de nuestras contrabridas para una adecuada instalación.

### CURVAS DE OPERACIÓN

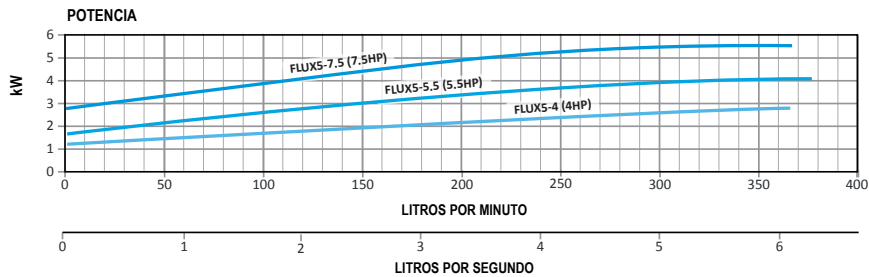
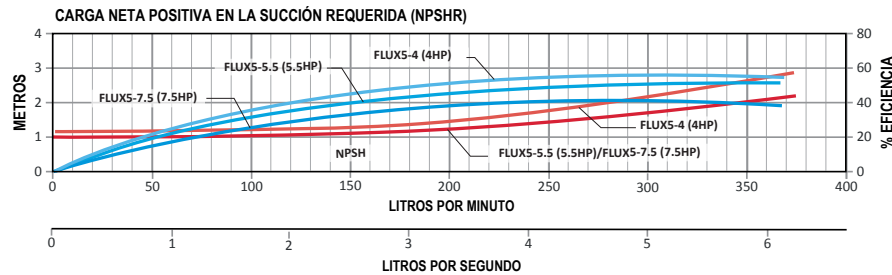
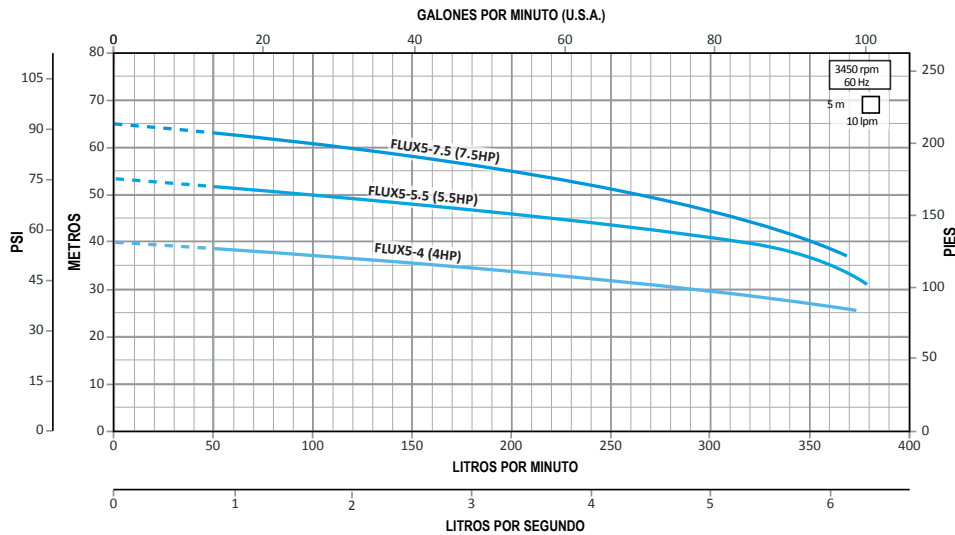

### TABLA DE ESPECIFICACIONES



Código	HP	KW	Fases x Volts	A	Succión x descarga	DMS*	Presión al cierre (m/psi)	Carga en metros (psi)			
								30 (42.6)	40 (56.8)	50 (71)	60 (85.2)
								Gasto (litros por minuto)			
FLUX5-43234	4	3	3 x 230/460	12/6			40/56.8	300			
FLUX5-5.53234	5.5	4	3 x 230/460	15/7.5	2" x 1.25"	2.5"	54/76.6	375	316	100	
FLUX5-7.53234	7.5	5.5	3 x 230/460	20/10			65/92.3		350	266	116

\*DMS: Diámetro mínimo recomendado para tubería de succión.

### KIT DE CONTRABRIDAS (venta por separado)

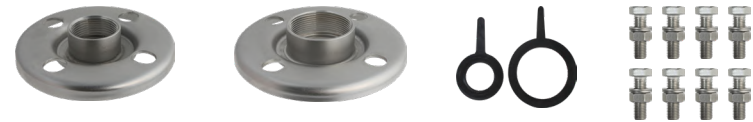

Código	Conexiones		Tipo de conexión	Material de construcción	Incluye	Peso (Kg)
	Succión	Descarga				
FLUXKB-DN2X1.25	2"	1.25"	Rosca NPT Hembra	Acero inoxidable 304	Contrabridas, empaques, tornillos y tuercas	3

NOTA: Se recomienda el uso de nuestras contrabridas para una adecuada instalación.

### CURVAS DE OPERACIÓN

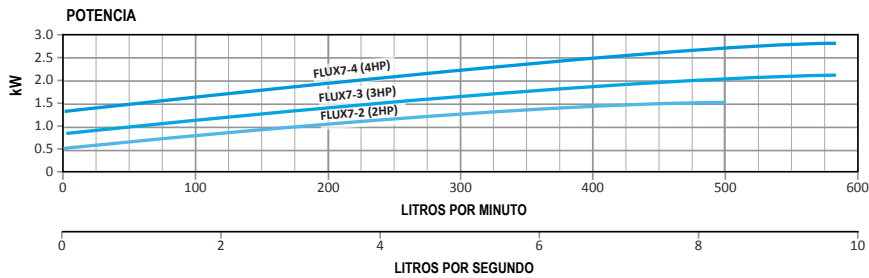
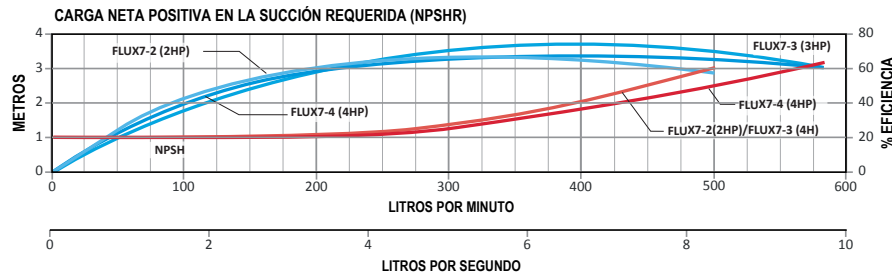
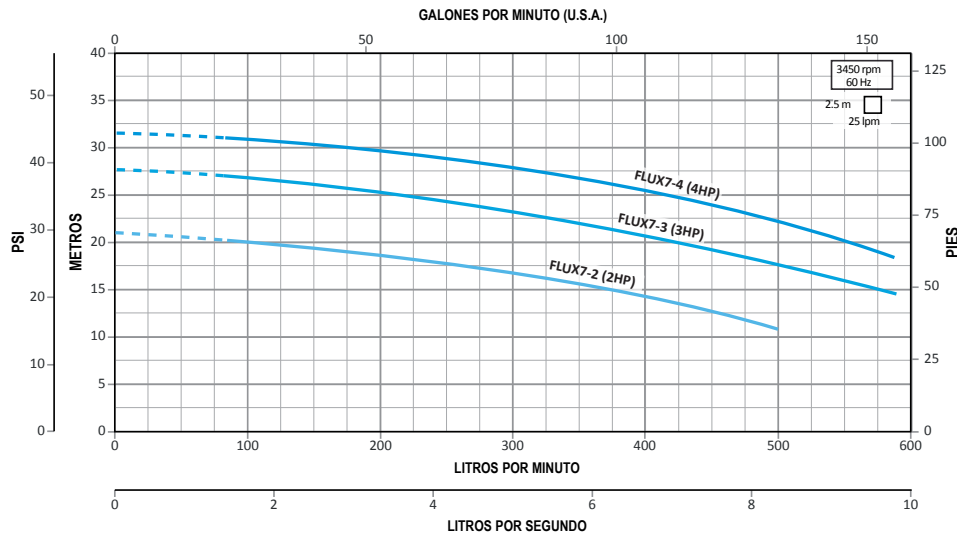

### TABLA DE ESPECIFICACIONES



Código	HP	KW	Fases x Volts	A	Succión x descarga	DMS*	Presión al cierre (m/psi)	Carga en metros (psi)			
								15 (21.3)	20 (28.4)	25 (35.5)	30 (42.6)
FLUX7-23234	2	1.5	3 x 230/460	7.3/3.7	2.5" x 1.5"	3"	21/29.8	375	83		
FLUX7-21230	2	1.5	1 x 230	10.2			21/29.8				
FLUX7-33234	3	2.2	3 x 230/460	9.5/4.8			27.5/39	583	416	216	
FLUX7-31230	3	2.2	1 x 230	14.5			27.5/39				
FLUX7-43234	4	3	3 x 230/460	12/6			32/45.4	550	416	166	

\*DMS: Diámetro mínimo recomendado para tubería de succión.

### KIT DE CONTRABRIDAS (venta por separado)



Código	Conexiones		Tipo de conexión	Material de construcción	Incluye	Peso (Kg)
	Succión	Descarga				
FLUXKB-DN2.5X1.5	2.5"	1.5"	Rosca NPT Hembra	Acero inoxidable 304	Contrabridas, empaques, tornillos y tuercas	3

NOTA: Se recomienda el uso de nuestras contrabridas para una adecuada instalación.

### CURVAS DE OPERACIÓN

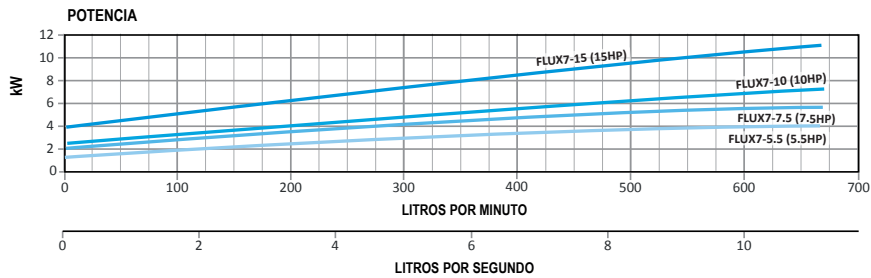
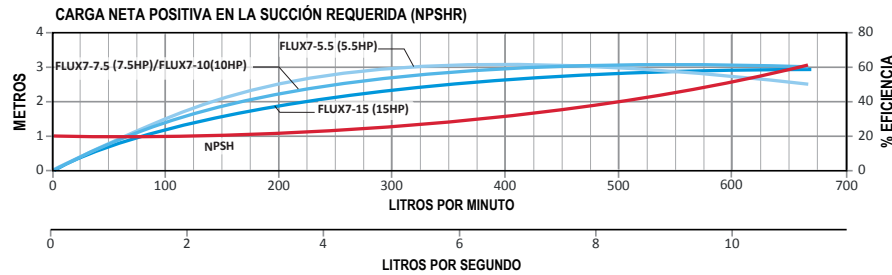
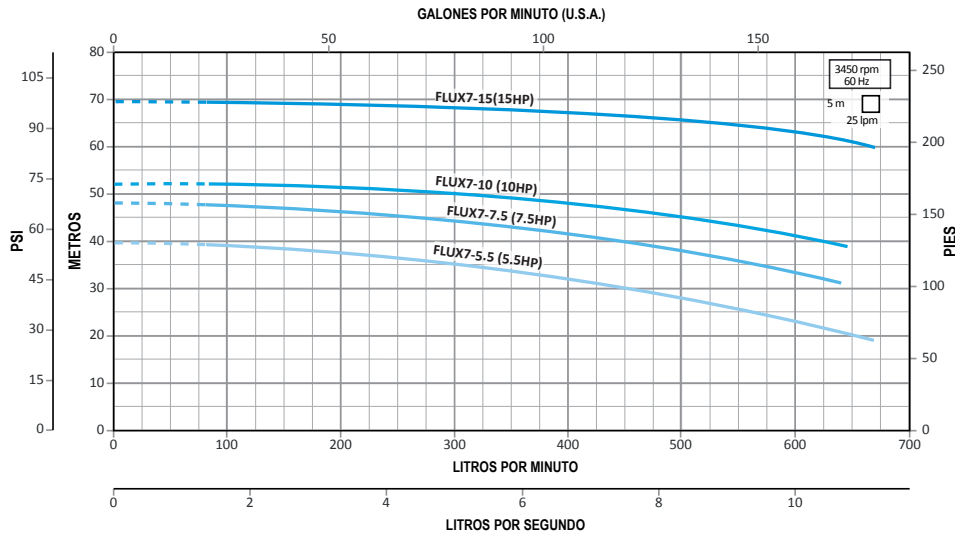

### TABLA DE ESPECIFICACIONES



Código	HP	KW	Fases x Volts	A	Succión x descarga	DMS*	Presión al cierre (m/psi)	Carga en metros (psi)				
								20 (28.4)	30 (42.6)	40 (56.8)	50 (71)	60 (85.2)
								Gasto (litros por minuto)				
FLUX7-5.53234	5.5	4	3 x 230/460	15/7.5	2.5" x 1.5"	3"	40/56.8	650	450			
FLUX7-7.53234	7.5	5.5		20/10			48/68		666	433		
FLUX7-103234	10	7.5		26/13			52/73.8			625	300	
FLUX7-153234	15	11		36.5/18.3			70/99.4					666

\*DMS: Diámetro mínimo recomendado para tubería de succión.

### KIT DE CONTRABRIDAS (venta por separado)



Código	Conexiones		Tipo de conexión	Material de construcción	Incluye	Peso (Kg)
	Succión	Descarga				
FLUXKB-DN2.5X1.5	2.5"	1.5"	Rosca NPT Hembra	Acero inoxidable 304	Contrabridas, empaques, tornillos y tuercas	3

NOTA: Se recomienda el uso de nuestras contrabridas para una adecuada instalación.

### CURVAS DE OPERACIÓN

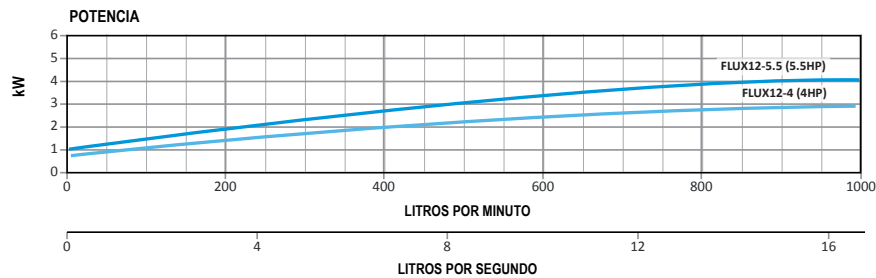
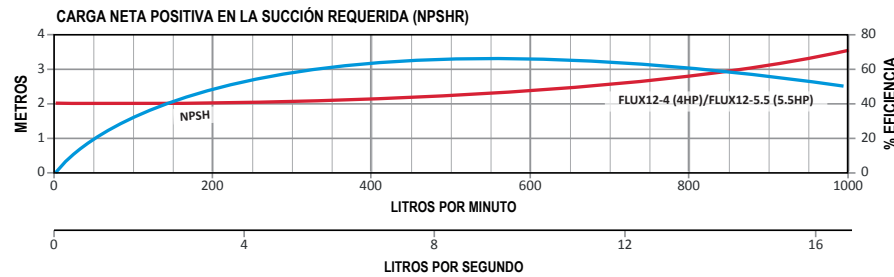
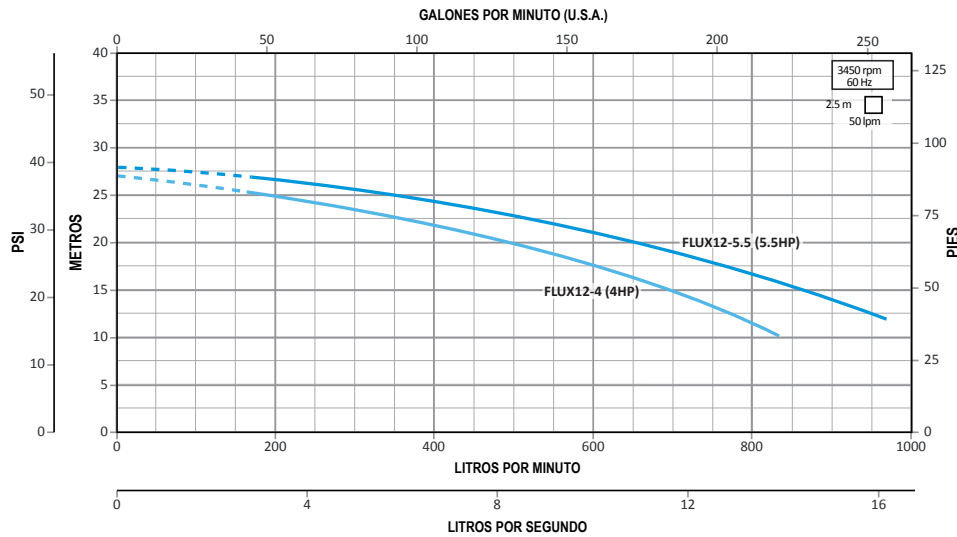

### TABLA DE ESPECIFICACIONES



Código	HP	KW	Fases x Volts	A	Succión x descarga	DMS*	Presión al cierre (m/psi)	Carga en metros (psi)			
								10 (14.2)	15 (21.3)	20 (28.4)	25 (35.5)
								Gasto (litros por minuto)			
FLUX12-43234	4	3	3 x	12/6	2.5" x 2"	3"	27/38.3	833	683	500	166
FLUX12-5.53234	5.5	4	230/460	15/7.5				858	666	350	

\*DMS: Diámetro mínimo recomendado para tubería de succión.

### KIT DE CONTRABRIDAS (venta por separado)



Código	Conexiones		Tipo de conexión	Material de construcción	Incluye	Peso (Kg)
	Succión	Descarga				
FLUXKB-DN2.5X2	2.5"	2"	Rosca NPT Hembra	Acero inoxidable 304	Contrabridas, empaques, tornillos y tuercas	3.3

NOTA: Se recomienda el uso de nuestras contrabridas para una adecuada instalación.



### CURVAS DE OPERACIÓN

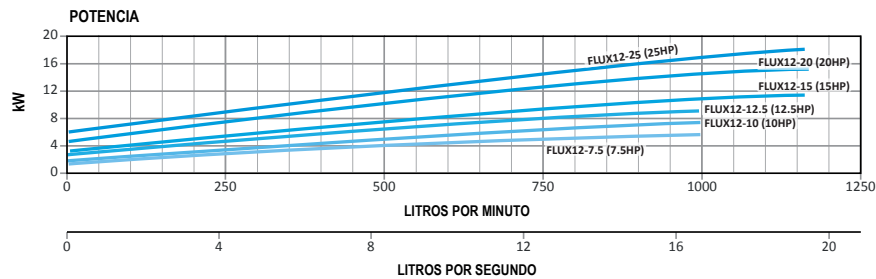
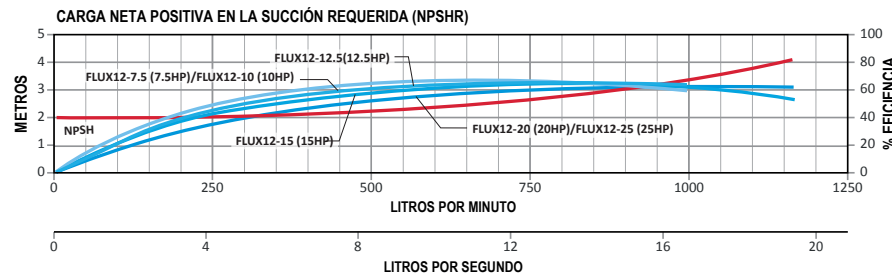
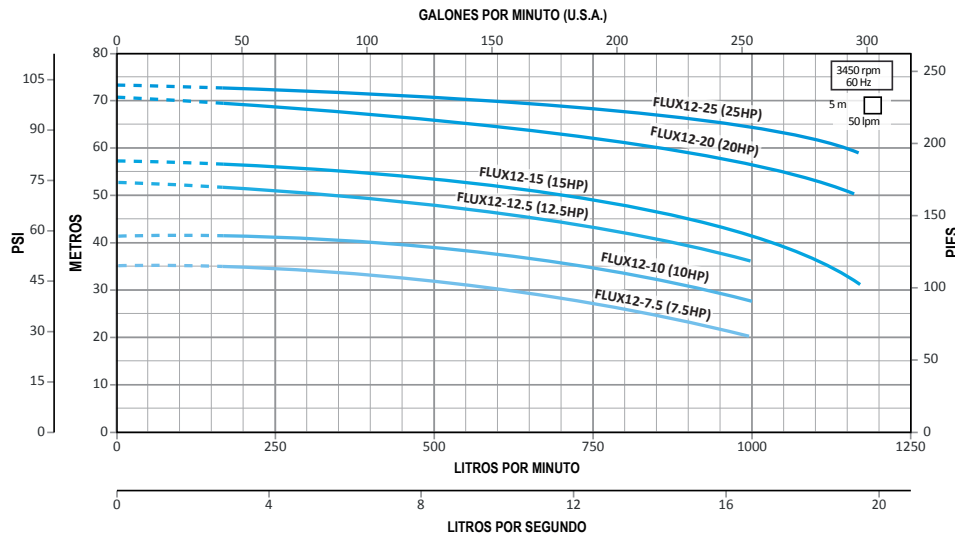

### TABLA DE ESPECIFICACIONES



Código	HP	KW	Fases x Volts	A	Succión x descarga	DMS*	Presión al cierre (m/psi)	Carga en metros (psi)						
								20 (28.4)	30 (42.6)	40 (56.8)	50 (71)	60 (85.2)	70 (99)	
FLUX12-7.53234	7.5	5.5	3x230/460	20/10	2.5" x 2"	3"	35/49.7	333	633					
FLUX12-103234	10	7.5	3x230/460	26/13			41/58.2	933	400					
FLUX12-12.53234	12.5	9.2	3x230/460	31.7/15.9			52/53.8		866	333				
FLUX12-153234	15	11	3x230/460	36.5/18.3			57/80.9		1025	700				
FLUX12-203234	20	15	3x230/460	49/24.5			70/99.4				1166	841	116	
FLUX12-253234	25	18.5	3x230/460	59/29.5			74/105						1150	566

\*DMS: Diámetro mínimo recomendado para tubería de succión.

### KIT DE CONTRABRIDAS (venta por separado)



Código	Conexiones		Tipo de conexión	Material de construcción	Incluye	Peso (Kg)
	Succión	Descarga				
FLUXKB-DN2.5X2	2.5"	2"	Rosca NPT Hembra	Acero inoxidable 304	Contrabridas, empaques, tornillos y tuercas	3.3

NOTA: Se recomienda el uso de nuestras contrabridas para una adecuada instalación.

### CURVAS DE OPERACIÓN

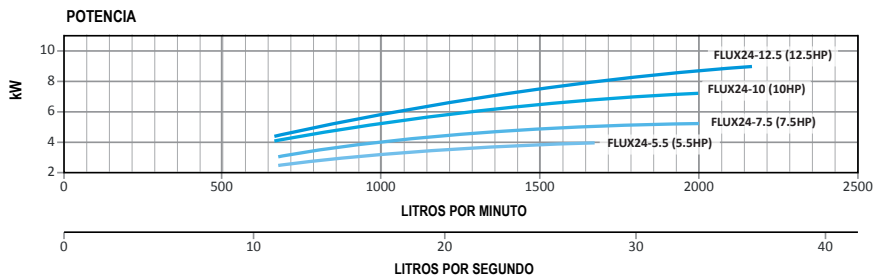
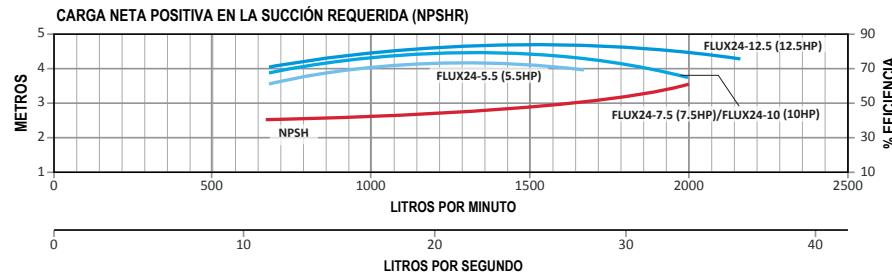
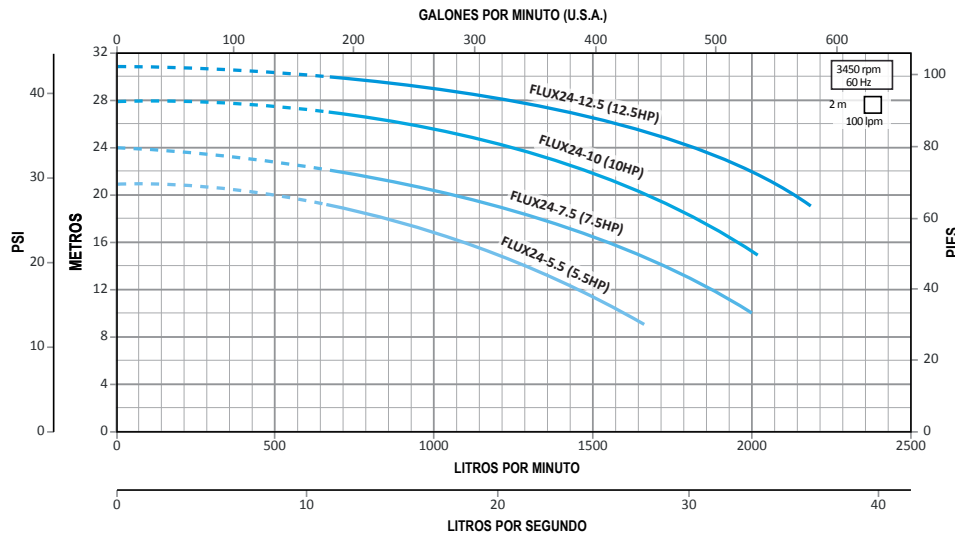

### TABLA DE ESPECIFICACIONES



Código	HP	KW	Fases x Volts	A	Succión x descarga	DMS*	Presión al cierre (m/psi)	Carga en metros (psi)				
								12 (17)	16 (22.7)	20 (28.4)	24 (34)	28 (39.7)
								Gasto (litros por minuto)				
FLUX24-5.53234	5.5	4	3 x 230/460	15/7.5	3" x 2.5"	4"	21/29.8	1450	1083	500		
FLUX24-7.53234	7.5	5.5		20/10			24/34	1841	1516	1050		
FLUX24-103234	10	7.5		26/13			28/39.7		1966	1666	1216	
FLUX24-12.53234	12.5	9.2		31.7/15.9			31/44			2133	1833	1216

\*DMS: Diámetro mínimo recomendado para tubería de succión.

### KIT DE CONTRABRIDAS (venta por separado)

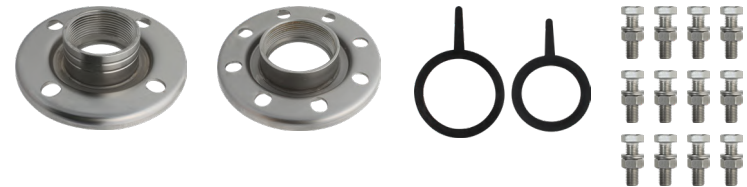

Código	Conexiones		Tipo de conexión	Material de construcción	Incluye	Peso (Kg)
	Succión	Descarga				
FLUXKB-DN3X2.5	3"	2.5"	Rosca NPT Hembra	Acero inoxidable 304	Contrabridas, empaques, tornillos y tuercas	4.4

NOTA: Se recomienda el uso de nuestras contrabridas para una adecuada instalación.

### CURVAS DE OPERACIÓN

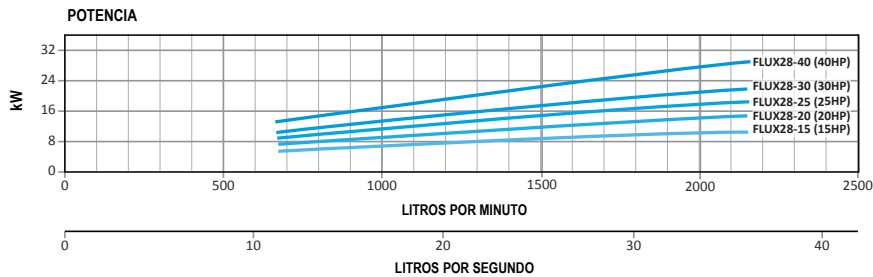
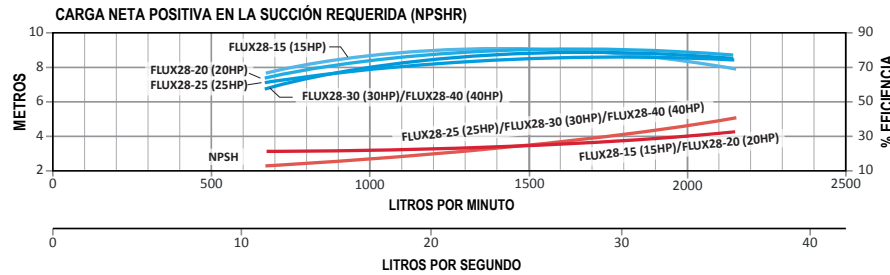
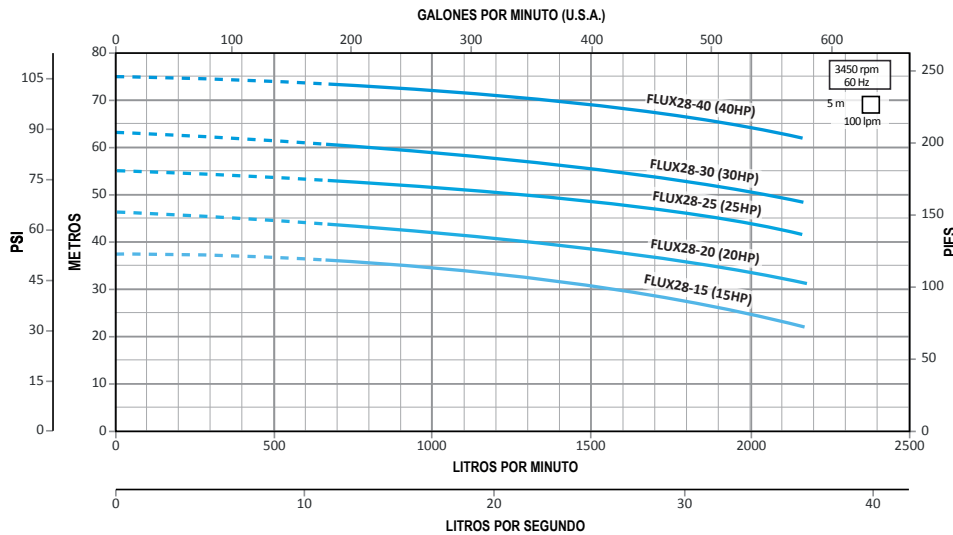

### TABLA DE ESPECIFICACIONES



Código	HP	KW	Fases x Volts	A	Succión x descarga	DMS*	Presión al cierre (m/psi)	Carga en metros (psi)					
								30	40	50	60	70	
								(42.6)	(56.8)	(71)	(85.2)	(99)	
									Gasto (litros por minuto)				
FLUX28-153234	15	11	3 x 230/460	36.5/18.3	3" x 2.5"	4"	38/53.9	1566					
FLUX28-203234	20	15		49/24.5			46/65.3	1333					
FLUX28-253234	25	18.5		59/29.5			55/78.1	1316					
FLUX28-303234	30	22		69.3/34.7			64/90.8	2033	833				
FLUX28-403234	40	30		93/46.5			75/106.5				1333		

\*DMS: Diámetro mínimo recomendado para tubería de succión.

### KIT DE CONTRABRIDAS (venta por separado)

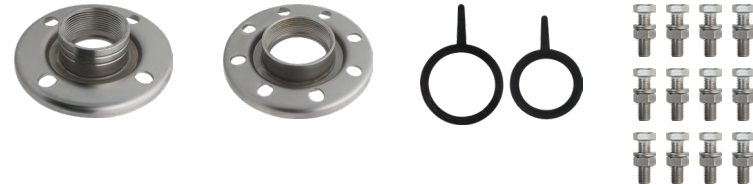

Código	Conexiones		Tipo de conexión	Material de construcción	Incluye	Peso (Kg)
	Succión	Descarga				
FLUXKB-DN3X2.5	3"	2.5"	Rosca NPT Hembra	Acero inoxidable 304	Contrabridas, empaques, tornillos y tuercas	4.4

NOTA: Se recomienda el uso de nuestras contrabridas para una adecuada instalación.

### CURVAS DE OPERACIÓN

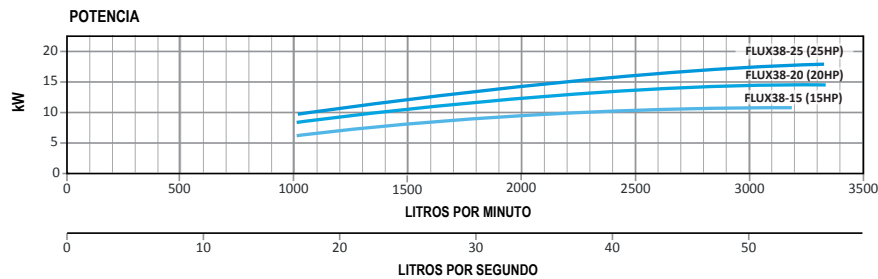
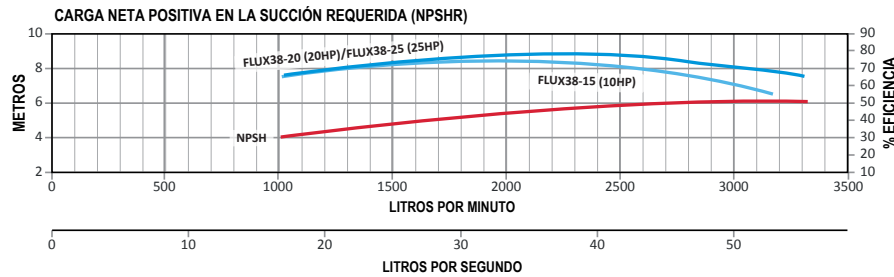
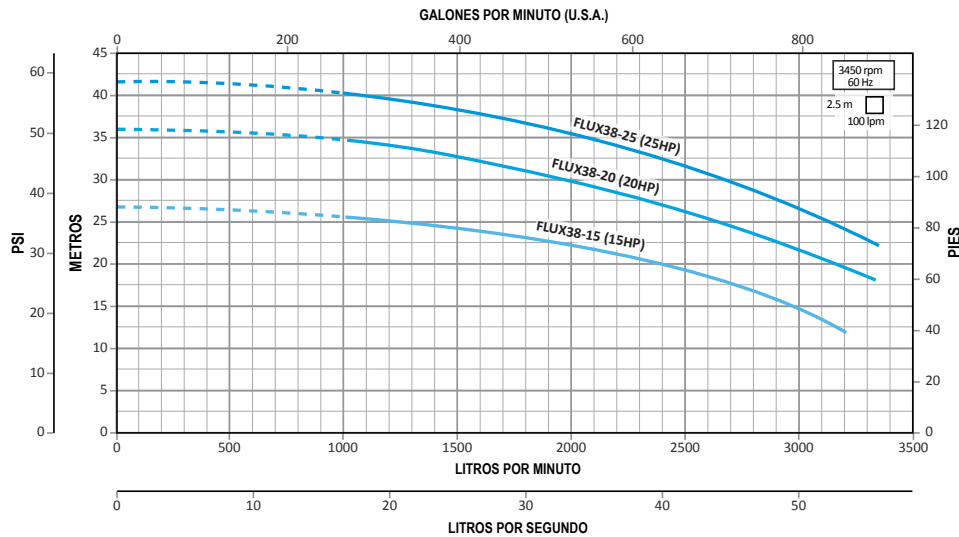

### TABLA DE ESPECIFICACIONES



Código	HP	KW	Fases x Volts	A	Succión x descarga	DMS*	Presión al cierre (m/psi)	Carga en metros (psi)					
								15 (21.3)	20 (28.4)	25 (35.5)	30 (42.6)	35 (49.7)	40 (56.8)
								Gasto (litros por minuto)					
FLUX38-153234	15	11	3 x 230/460	36.5/18.3	4" x 3"	5"	27/38.4	2966	2400	1250			
FLUX38-203234	20	15		49/24.5					3166	2666	2000	916	
FLUX38-253234	25	18.5		59/29.5					42/56.6		3133	2666	2050

\*DMS: Diámetro mínimo recomendado para tubería de succión.

### KIT DE CONTRABRIDAS (venta por separado)



Código	Conexiones		Tipo de conexión	Material de construcción	Incluye	Peso (Kg)
	Succión	Descarga				
FLUXKB-DN4X3	4"	3"	Rosca NPT Hembra	Acero inoxidable 304	Contrabridas, empaques, tornillos y tuercas	5.4

NOTA: Se recomienda el uso de nuestras contrabridas para una adecuada instalación.

### CURVAS DE OPERACIÓN

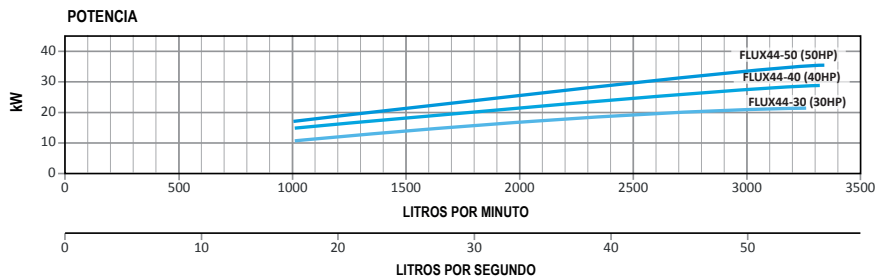
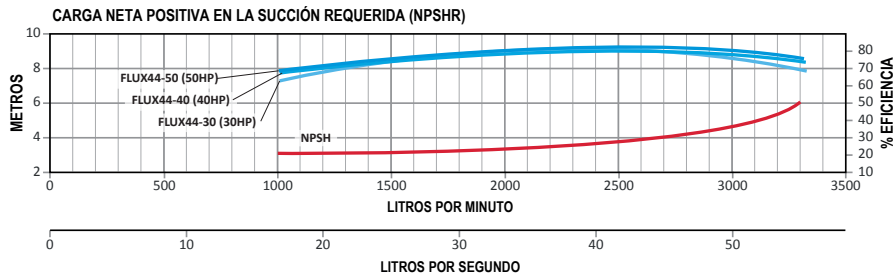
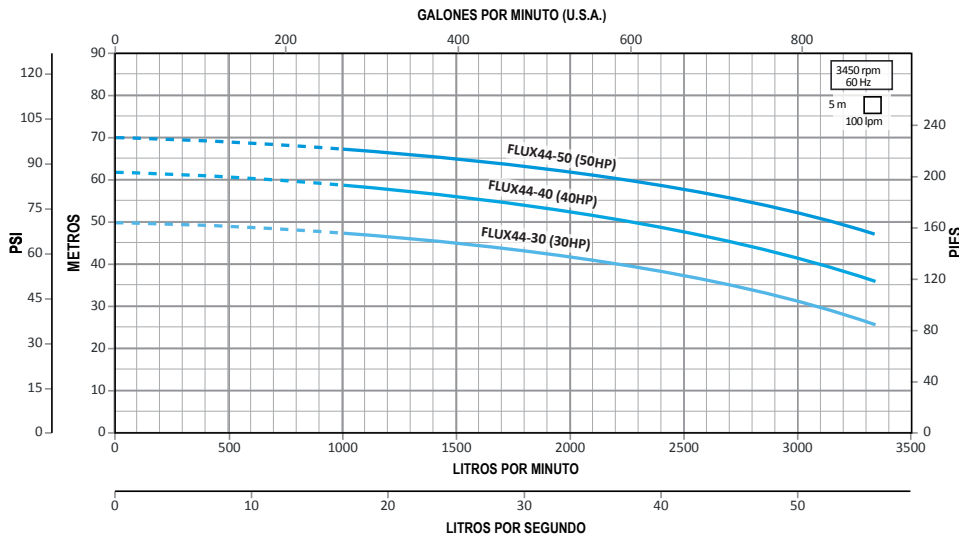

### TABLA DE ESPECIFICACIONES



Código	HP	KW	Fases x Volts	A	Succión x descarga	DMS*	Presión al cierre (m/psi)	Carga en metros (psi)			
								30 (42.6)	40 (56.8)	50 (71)	60 (85.2)
FLUX44-303234	30	22	3 x 230/460	70/35	4" x 3"	5"	50/71	3083	2250		
FLUX44-403234	40	30		93/46.5			61/86.6		3100	2283	666
FLUX44-503234	50	37		114/57			70/99.4			3166	2250

Gasto (litros por minuto)

\*DMS: Diámetro mínimo recomendado para tubería de succión.

### KIT DE CONTRABRIDAS (venta por separado)



Código	Conexiones		Tipo de conexión	Material de construcción	Incluye	Peso (Kg)
	Succión	Descarga				
FLUXKB-DN4X3	4"	3"	Rosca NPT Hembra	Acero inoxidable 304	Contrabridas, empaques, tornillos y tuercas	5.4

NOTA: Se recomienda el uso de nuestras contrabridas para una adecuada instalación.

### CURVAS DE OPERACIÓN

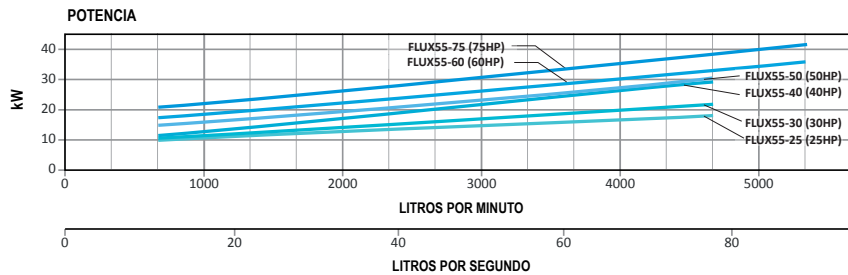
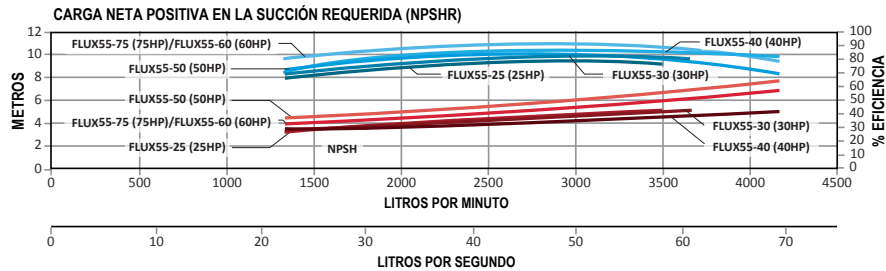
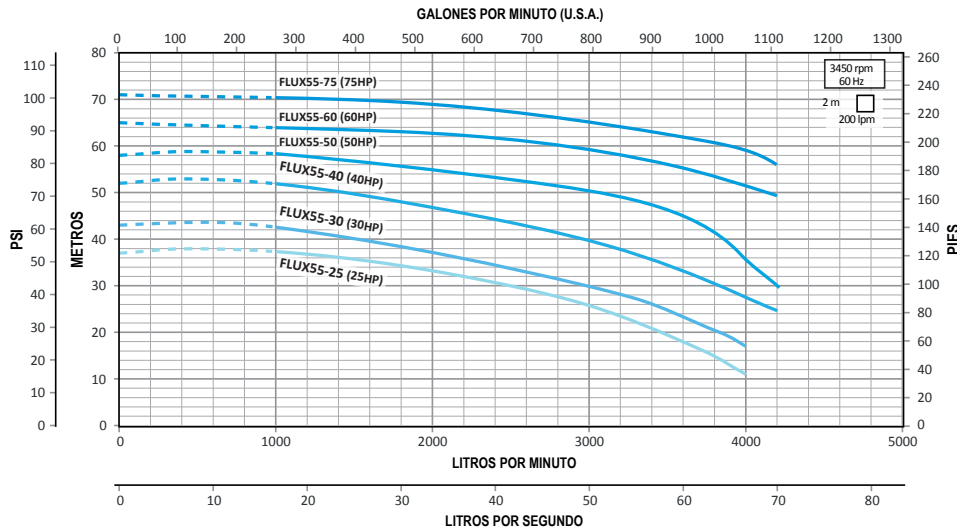

### TABLA DE ESPECIFICACIONES

**INCLUYE CONTRABRIDAS**



Código	HP	KW	Fases x Volts	A	Succión x descarga	DMS*	Presión al cierre (m/psi)	Carga en metros (psi)					
								20 (28.4)	30 (42.6)	40 (56.8)	50 (71)	60 (85.2)	70 (99.4)
								Gasto (litros por minuto)					
FLUX55-253234	25	18.5	3 x 230/460	56.9/28.5	6" x 4"	8"	37/52.5	3420	2500				
FLUX55-303234	30	22		67.7/33.8			43/61.1	3800	2950	1500			
FLUX55-403234	40	30		91.6/45.8			52/73.9		3800	2950	1400		
FLUX55-503234	50	37		112.2/56.1			58/82.4			3850	3000		
FLUX55-603234	60	45		134.1/67.0			65/92.4				4150	2800	
FLUX55-753234	75	55		163.9/81.9			71/100.9					3900	1000

\*DMS: Diámetro mínimo recomendado para tubería de succión.

### KIT DE CONTRABRIDAS (incluidas)

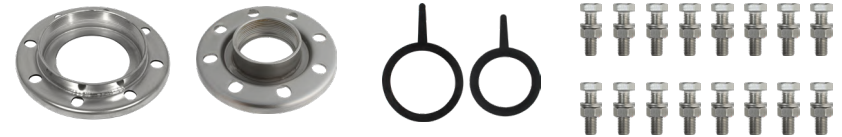

Código	Conexiones		Tipo de conexión	Material de construcción	Incluye	Peso (Kg)
	Succión	Descarga				
FLUXKB-DN6X4	6"	4"	Rosca NPT Hembra	Acero inoxidable 304	Contrabridas, empaques, tornillos y tuercas	3.8

NOTA: Se recomienda el uso de nuestras contrabridas para una adecuada instalación.

### CURVAS DE OPERACIÓN

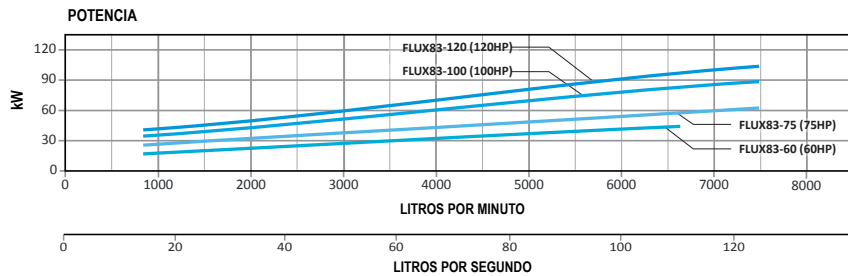
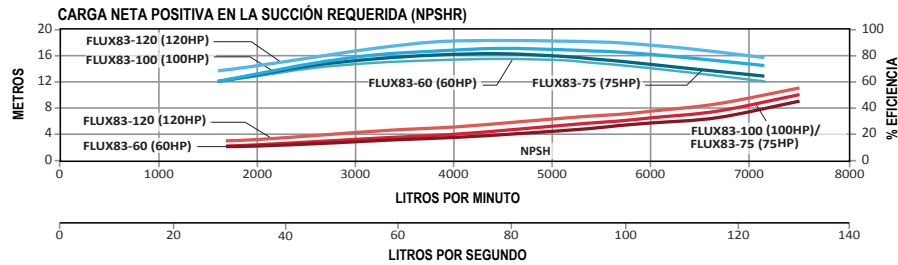
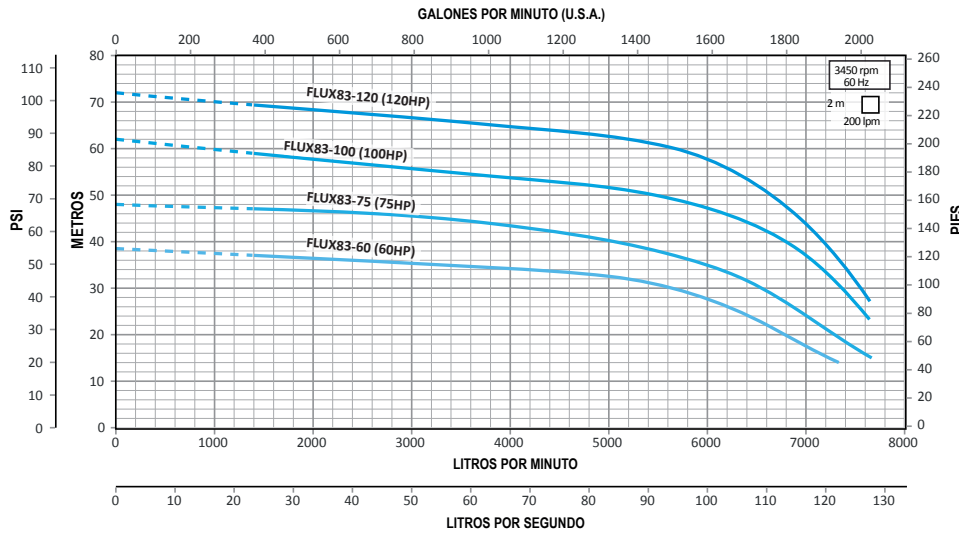

### TABLA DE ESPECIFICACIONES

**INCLUYE  
CONTRABRIDAS**



Código	HP	KW	Fases x Volts	A	Succión x descarga	DMS*	Presión al cierre (m/psi)	Carga en metros (psi)					
								20 (28.4)	30 (42.6)	40 (56.8)	50 (71)	60 (85.2)	70 (99.4)
								Gasto (litros por minuto)					
FLUX83-603234	60	45	3 x 230/460	134.1/67.0	6" x 6"	8"	38/54.0	6800	5600				
FLUX83-753234	75	55		163.9/81.9			48/68.3	7300	6550	5000			
FLUX83-1003234	100	75		222.3/111.2			62/88.2		7380	6800	5450	800	
FLUX83-1203234	120	90		264.2/132.1			72/102.4		7580	7200	6620	5600	1000

\*DMS: Diámetro mínimo recomendado para tubería de succión.

### KIT DE CONTRABRIDAS (incluidas)



Código	Conexiones		Tipo de conexión	Material de construcción	Incluye	Peso (Kg)
	Succión	Descarga				
FLUXKB-DN6X6	6"	6"	Rosca NPT Hembra	Acero inoxidable 304	Contrabridas, empaques, tornillos y tuercas	5.1

NOTA: Se recomienda el uso de nuestras contrabridas para una adecuada instalación.

**DIMENSIONES Y PESOS**

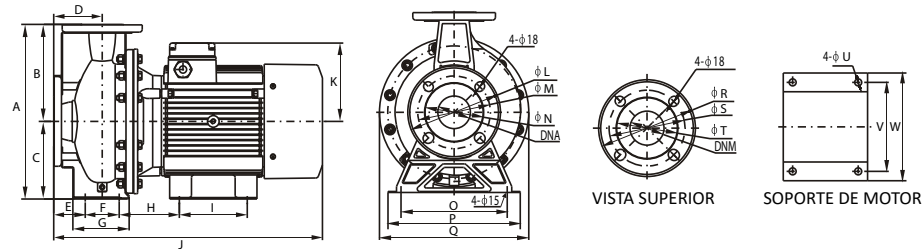

Código	Dimensiones																							Peso (kg)		
	(mm)																					(Pulgadas)				
	A	B	C	D	E	F	G	H	I	J	K	φL	φM	φN	O	P	Q	φR	φS	φT	φU	V	W		DNA	DNM
FLUX4-1.5								95	90	395	134															
FLUX4-2	255	112	143	80	45	70	115	111	100	428	119	165	125	96	160	190	210	140	100	76	12	125	155	2"	1.25"	
FLUX4-3																						160	190			

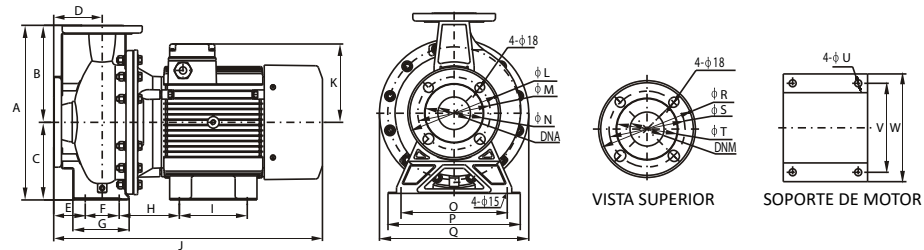

Código	Dimensiones																							Peso (kg)		
	(mm)																					(Pulgadas)				
	A	B	C	D	E	F	G	H	I	J	K	φL	φM	φN	O	P	Q	φR	φS	φT	φU	V	W		DNA	DNM
FLUX5-4								109	100	460	119											12	160	190		
FLUX5-5.5	340	160	180	80	45	70	118	114	140	498	142	165	125	96	190	240	300	140	100	76	15	190	225	2"	1.25"	
FLUX5-7.5								122		532	162												230			



## DIMENSIONES Y PESOS

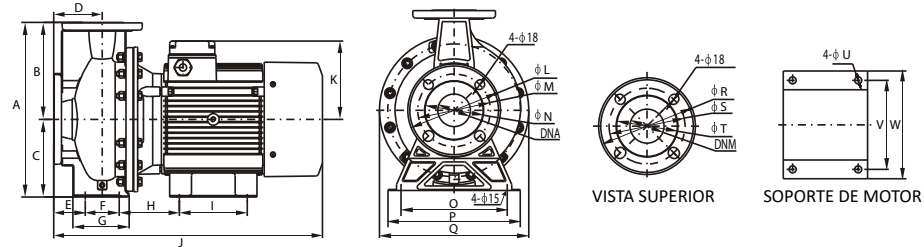

Código	Dimensiones																							Peso (kg)				
	(mm)																					(Pulgadas)						
	A	B	C	D	E	F	G	H	I	J	K	φL	φM	φN	O	P	Q	φR	φS	φT	φU	V	W		DNA	DNM		
FLUX7-2	255	112	143	80	45	70	115	95	90	395	134	185	145	115	160	190	210	150	110	80	12	125	155	2.5"	1.5"	20		
FLUX7-3							111	100	425	119	190											240	250			160	190	25
FLUX7-4	292	132	160				118	460	190	240	250											160	190			31		

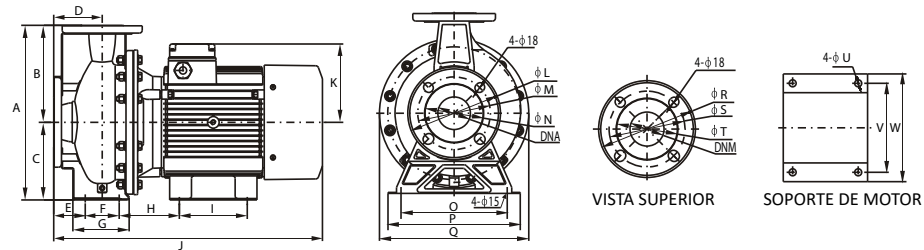

Código	Dimensiones																							Peso (kg)						
	(mm)																					(Pulgadas)								
	A	B	C	D	E	F	G	H	I	J	K	φL	φM	φN	O	P	Q	φR	φS	φT	φU	V	W		DNA	DNM				
FLUX7-5.5	292	132	160	80	45	70	118	114	140	498	142	185	145	115	190	240	250	150	110	80	15	190	225	2.5"	1.5"	39				
FLUX7-7.5								124		554	162												212			264	300	190	230	53
FLUX7-10	360	160	200					100		65	592												179			212	264	300	190	230
FLUX7-15				161	623	179	216	255			81																			

**DIMENSIONES Y PESOS**

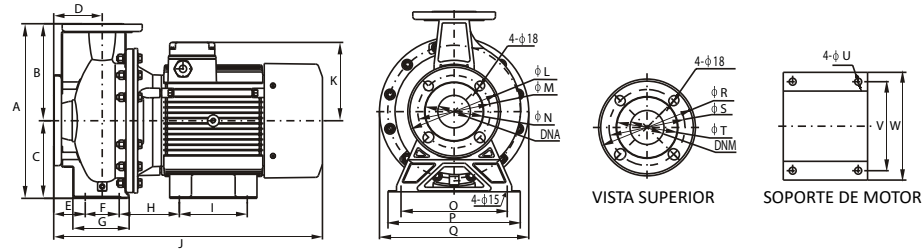

Código	Dimensiones																						Peso (kg)			
	(mm)																				(Pulgadas)					
	A	B	C	D	E	F	G	H	I	J	K	$\phi L$	$\phi M$	$\phi N$	O	P	Q	$\phi R$	$\phi S$	$\phi T$	$\phi U$	V		W	DNA	DNM
FLUX12-4	292	132	160	80	45	70	115	110	100	455	119	185	145	115	190	240	250	165	125	96	12	160	190	2.5"	2"	31
FLUX12-5.5								114	140	498	142										15	190	225			

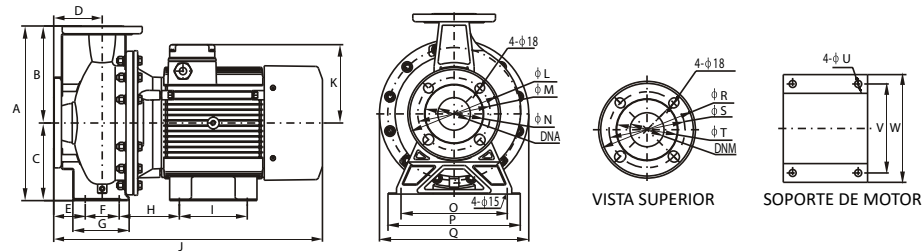

Código	Dimensiones																						Peso (kg)			
	(mm)																				(Pulgadas)					
	A	B	C	D	E	F	G	H	I	J	K	$\phi L$	$\phi M$	$\phi N$	O	P	Q	$\phi R$	$\phi S$	$\phi T$	$\phi U$	V		W	DNA	DNM
FLUX12-7.5	360	160	200	100	65	70	118	124	140	554	179	185	145	115	212	264	300	165	125	96	15	190	230	2.5"	2"	53
FLUX12-10								162		592																64
FLUX12-12.5								623		72																
FLUX12-15								161		179																81
FLUX12-20								665		95																
FLUX12-25								175		254																725



**DIMENSIONES Y PESOS**

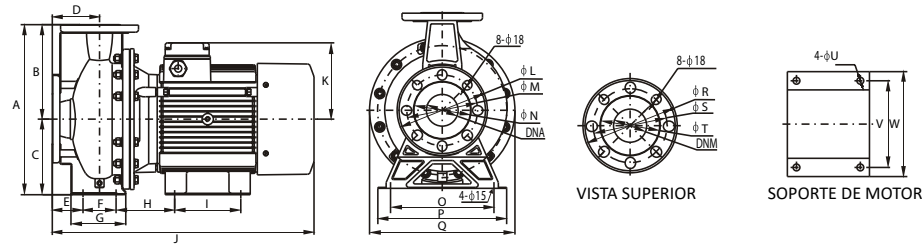

Código	Dimensiones																							Peso (kg)		
	(mm)																			(Pulgadas)						
	A	B	C	D	E	F	G	H	I	J	K	φL	φM	φN	O	P	Q	φR	φS	φT	φU	V	W		DNA	DNM
FLUX38-15										669																
FLUX38-20	405	180	225	125	78	95	176	183	140	711	179	220	180	152	250	290	256	200	160	132	15	216	255	4"	3"	
FLUX38-25								152		769	255											254	320			

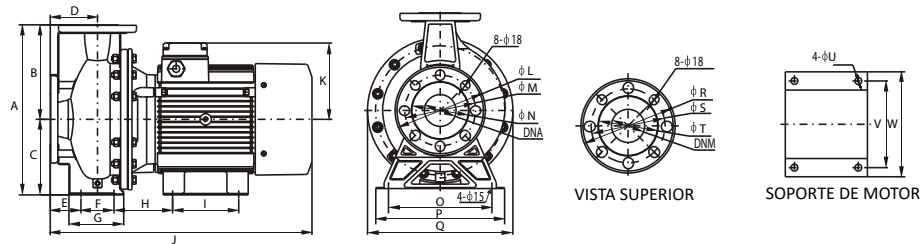

Código	Dimensiones																							Peso (kg)		
	(mm)																			(Pulgadas)						
	A	B	C	D	E	F	G	H	I	J	K	φL	φM	φN	O	P	Q	φR	φS	φT	φU	V	W		DNA	DNM
FLUX44-30	430	180						180	241	811	275										15	279	355			
FLUX44-40			250	125	78	95	176					220	180	152	280	320	300	200	160	132		18.5	318	386	4"	3"
FLUX44-50	450	200						188	305	880	308															

**DIMENSIONES Y PESOS**

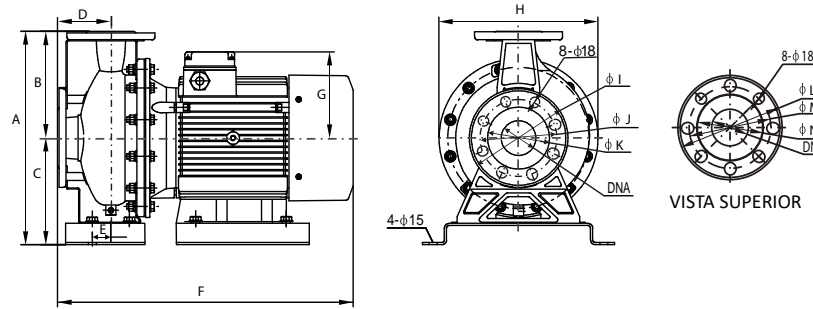

Código	Dimensiones																Peso (kg)
	(mm)														(Pulgadas)		
	A	B	C	D	E	F	G	H	φI	φJ	φK	φL	φM	φN	DNA	DNM	
FLUX55-25	405	230	175	105	66	790	230	315	250	210	180	220	180	152	6"	4"	148
FLUX55-30			60		820	275	356	200									
FLUX55-40	425	195	885		320	400	244										
FLUX55-50	482	272	210		886	295	269										
FLUX55-60	505	270	235		905	330	314										
FLUX55-75	530	275	255		995	362	485	392									

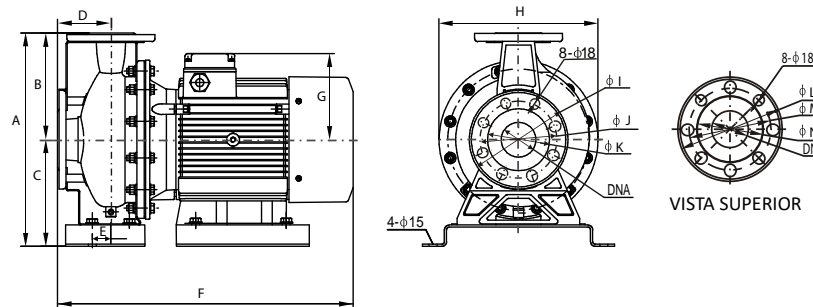

Código	Dimensiones																Peso (kg)
	(mm)														(Pulgadas)		
	A	B	C	D	E	F	G	H	φI	φJ	φk	φL	φN	φN	DNA	DNM	
FLUX83-60	565	315	250	135	60	950	330	440	285	240	206	250	210	180	6"	6"	316
FLUX83-75			1040			370	480	396									
FLUX83-100	595	280	70		1095	384	540	535									
FLUX83-120						395	542	569									